

THESE DRAWINGS ARE THE PROPERTY OF QUALTEK ELECTRONICS AND NOT TO BE REPRODUCED FOR OR COMMUNICATED TO A THIRD PARTY WITHOUT THE EXPRESS WRITTEN PERMISSION OF AN OFFICER OF QUALTEK ELECTRONICS.

REVISION			
REV.	DESCRIPTION	DATE	APPROVED
B	RoHS Compliancy	06-01-06	DP
C	Graphics Update	03-21-08	DP

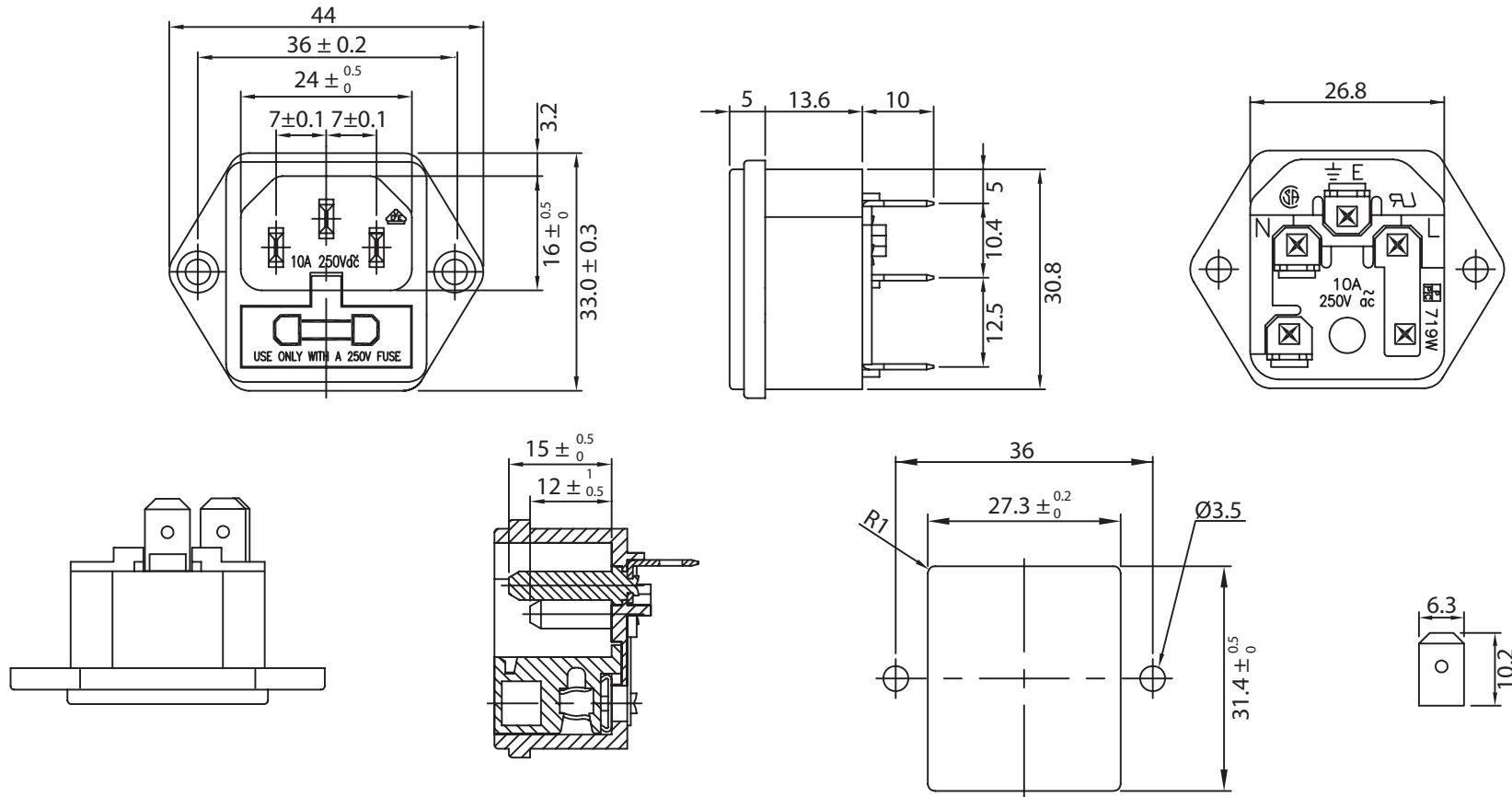

Distributed by Electro-Stock, Inc. sales@electrostock.com
630-682-1542 Fax 630-682-1562 http://www.electrostock.com

CONTROLLED

NOTES:

RATING: 10A 250V AC
DIELECTRIC STRENGTH: 2000V AC/1mA 1MIN
INSULATION RESISTANCE: 100M OHM 500VDC MIN
APPROVALS: UL,CSA,VDE
DUAL FUSEHOLDER, ONE ACTIVE, ONE SPARE
FUSES NOT INCLUDED - RECOMMENDED SIZE: 5 X 20mm
RoHS COMPLIANT

Dim range (mm)	Tolerance +/- (mm)	Qualtek Electronics Corp. PPC DIVISION		
		Part Number:	719W-00/04	RoHS Compliant
0-1	0.15	Description: AC RECEPTACLE		
1-6	0.20		UNIT: mm	REV. C
6-18	0.30			
18-50	0.50			
50-120	0.70	Drawn / Date	Checked / Date	Approved / Date
120-250	0.90	B.Zhang 01-27-04	01-27-04	JJH / 01-27-04
250-500	1.20			