

HGN-375 IEC 60320 INLET SOCKET WITH SWITCH, SINGLE AND DOUBLE FUSE HOLDER, FLANGE MOUNT



FEATURES

The HGN-375 protects electronic equipment from common and differential mode line interference in the range of 10KHz up to 30MHz. This "combi-unit" is equipped with IEC connector, fuse holder for one or two 5 x 20 mm fuses, 2 pole on/off switch and fully enclosed metal housing.

These filters are also available for Medical equipment with low leakage current. HGN-375 series filters are high performance filters and have been designed to bring various medical equipments into compliance with EN55011 and FCC Part 15J, Class B conducted emissions limits.

APPLICATIONS

Computer & networking equipment, Measuring & control equipment, Data processing equipment, laboratory instruments, Switching power supplies, other electronic equipment.

TECHNICAL DATA

- Rated Voltage: 125/250VAC
- Rated Current: 1A, 2A, 4A, 6A, 10A
- Power Line Frequency: 50/60Hz
- Max. Leakage Current each
Line to Ground:
 - @ 250VAC 50Hz: 0.5mA, max
 - @ 250VAC 50Hz: 2 μ A*, max
- Hipot Rating (one minute)
 - Line to Ground: 2250VDC
 - Line to Line: 1450VDC
- Temperature Range: -25C to +85C

* Medical application

MECHANICAL DIMENSIONS (Unit: mm)

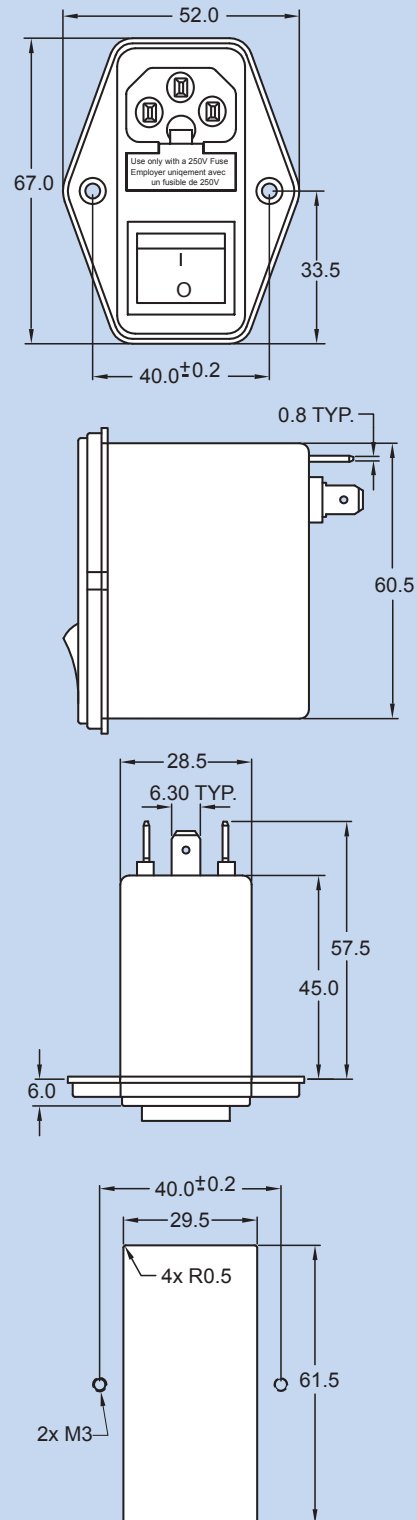

Specifications subject to change without notice. Dimensions (mm). See Appendix A for recommended power cord. See PDI full line catalog for detailed specifications on power cords.

HGN-375 Series Example & Ordering Code

HGN-375- **1** **M** - **F2**

CURRENT RATING (A):		= 1
		= 2
		= 4
		= 6
		= 10
		
SCHEMATIC:		= BLANK
STANDARD TYPE		= M
WITHOUT C(Y); C(X) ONLY		
FUSE OPTION:		= F1
1 FUSE (5X20MM), 6.3/0.25 QUICK CONNECT		
2 FUSE (5X20MM), 6.3/0.25 QUICK CONNECT		= F2

Attenuation Tables & Schematics

Non-Medical Applications

Insertion loss in dB (50 Ohm circuit)

Current Rating	L Value	Comm.Mode(L-G) MHz										Diff. mode(L-L) MHz									
		.01	.05	.1	.15	.5	1	5	10	30	.01	.05	.1	.15	.5	1	5	10	30		
1A	10.3mA	24	33	38	40	51	46	35	31	21	3	10	7	16	60	75	89	80	39		
2A	4.6mA	16	30	35	37	41	42	37	29	21	5	12	10	11	60	73	82	82	39		
4A	2.5mA	10	17	20	22	30	32	32	30	23	8	10	16	19	40	67	84	80	40		
6A	1.2mA	8	13	17	19	26	29	29	29	25	5	8	15	16	30	51	79	80	50		
10A	0.8mA	5	6	15	17	30	51	79	80	51	2	9	13	17	26	33	53	60	40		

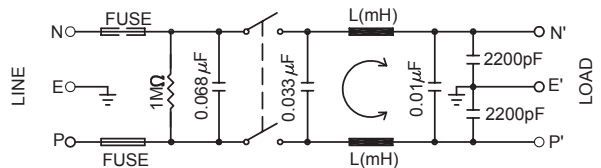

Medical Applications

Insertion loss in dB (50 Ohm circuit)

Current Rating	L Value	Comm.Mode(L-G) MHz										Diff. mode(L-L) MHz									
		.01	.05	.1	.15	.5	1	5	10	30	.01	.05	.1	.15	.5	1	5	10	30		
1A	10.3mA	23	32	38	41	51	48	36	31	22	2	10	8	15	60	75	84	80	39		
2A	4.6mA	18	30	35	36	41	42	37	30	21	5	12	10	10	60	73	82	83	36		
3A	2.5mA	10	18	20	22	30	32	32	30	22	8	10	17	19	40	67	84	80	33		
4A	1.2mA	8	13	17	19	26	29	29	29	24	5	7	15	17	30	51	80	80	41		
6A	0.8mA	8	13	16	19	25	28	29	29	24	5	5	15	18	30	51	79	80	51		

